



**CONFIDENTIAL**

THIS DOCUMENT AND INFORMATION CONTAINED HEREIN IS PROPRIETARY AND CONFIDENTIAL TO PRECOR STRENGTH INCORPORATED. RECIPIENTS OF THIS DOCUMENT AGREE THAT THIS DOCUMENT AND INFORMATION WILL NOT BE USED FOR ANY PURPOSE, REPRODUCED OR COPIED, OR DISCLOSED TO ANY THIRD PARTY, EITHER IN WHOLE OR IN PART WITHOUT PRIOR EXPRESS WRITTEN PERMISSION OF PRECOR STRENGTH, INCORPORATED.

**PRECOR** USA  
PRECOR STRENGTH, INC.

28936 AVE WILLIAMS  
VALENCIA, CA 91355  
TELEPHONE: 661-362-0300

SIGN IN BLUE OR BLACK INK ONLY		
DRWN BY	01.02.07	MGP
DWG CHK		
ENG	01.02.07	RSG
MPG ENG		
CS		
QA		
ID		
REG		

UNLESS OTHERWISE SPECIFIED:  
DIMENSIONS ARE IN INCHES  
TOLERANCES ARE:  
LIN .X=±0.1 .XXX=±0.010  
LIN .XX=±0.02 .XXXX=±0.0001  
ANGULAR: ±1.0°  
ALL DIMS AFTER PLATING  
BREAK ALL SHARP EDGES  
REMOVE ALL BURRS  
ALL ANGLES & BENDS 90°  
DWG PER ASME Y14.5M-1994  
DO NOT SCALE DRAWING  
ALL MACHINED SURFACES

PRODUCT:		STRENGTH
ASSEMBLY CONNECTION, 10.5, W/ 1 PULLEY HSG		
DWG. NO.	CW31868-402	SUBREV A

SIZE	PAGE	OF
C	1	1

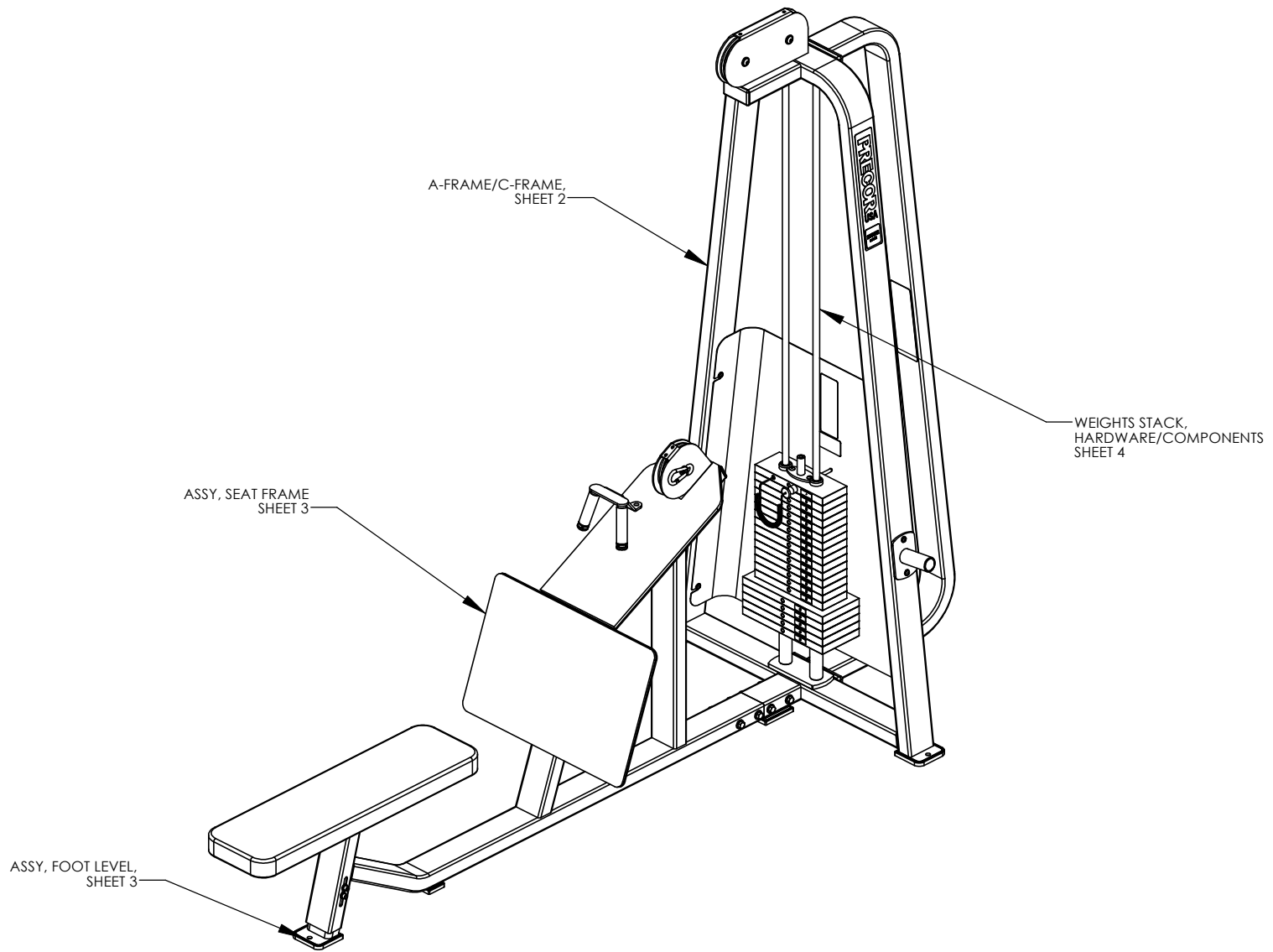

P/N: CW31931-402	SUBREV: C
DRAWN BY: JEC	DATE: 09.11.08
	SHEET 1 OF 4

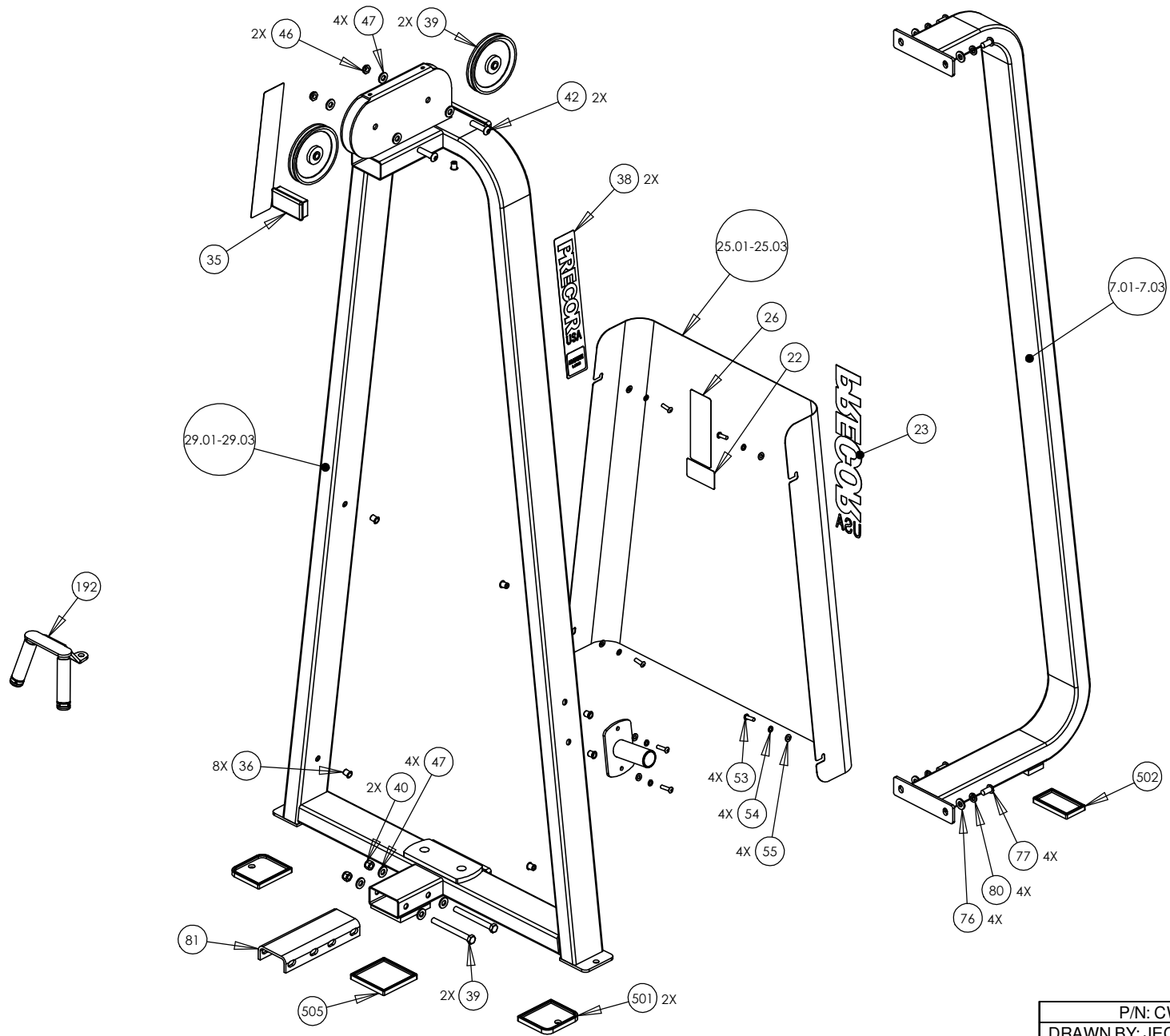

P/N: CW31931-402	SUBREV: C
DRAWN BY: JEC	DATE: 09.11.08
SHEET 2 OF 4	

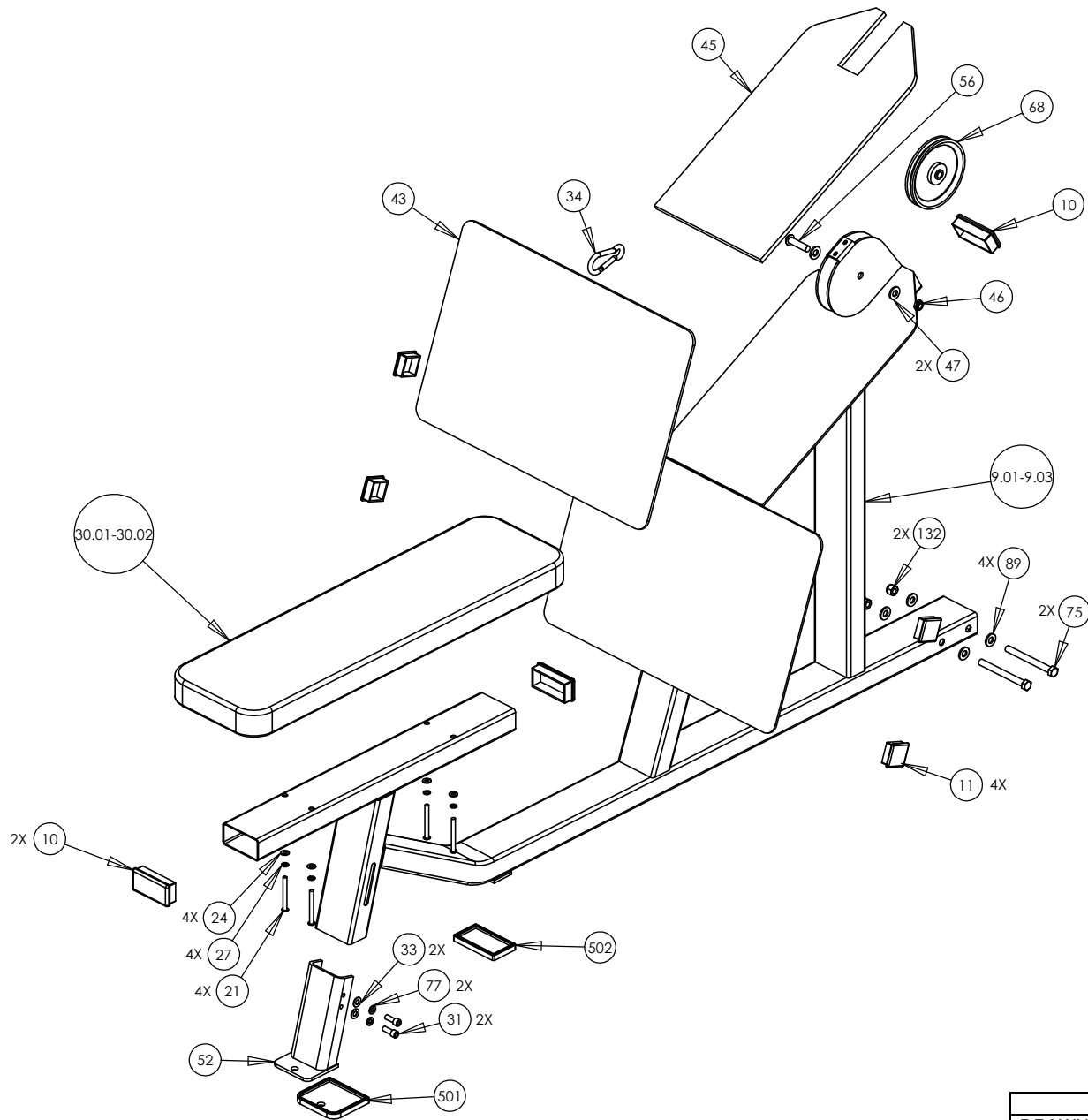

P/N: CW31931-402		SUBREV: C
DRAWN BY: JEC	DATE: 09.11.08	SHEET 3 OF 4

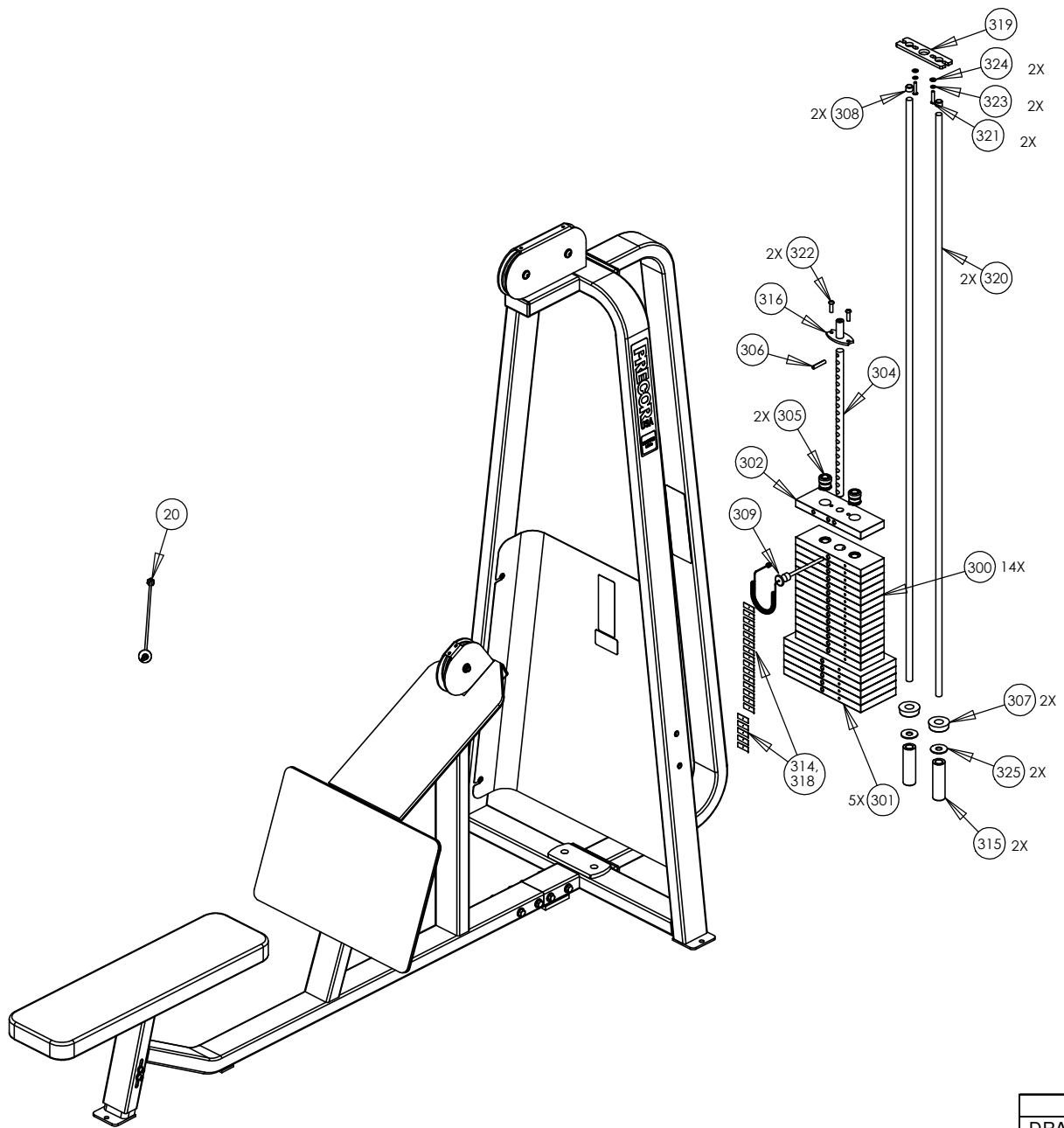

P/N: CW31931-402	SUBREV: C
DRAWN BY: JEC	DATE: 09.11.08
SHEET 4 OF 4	

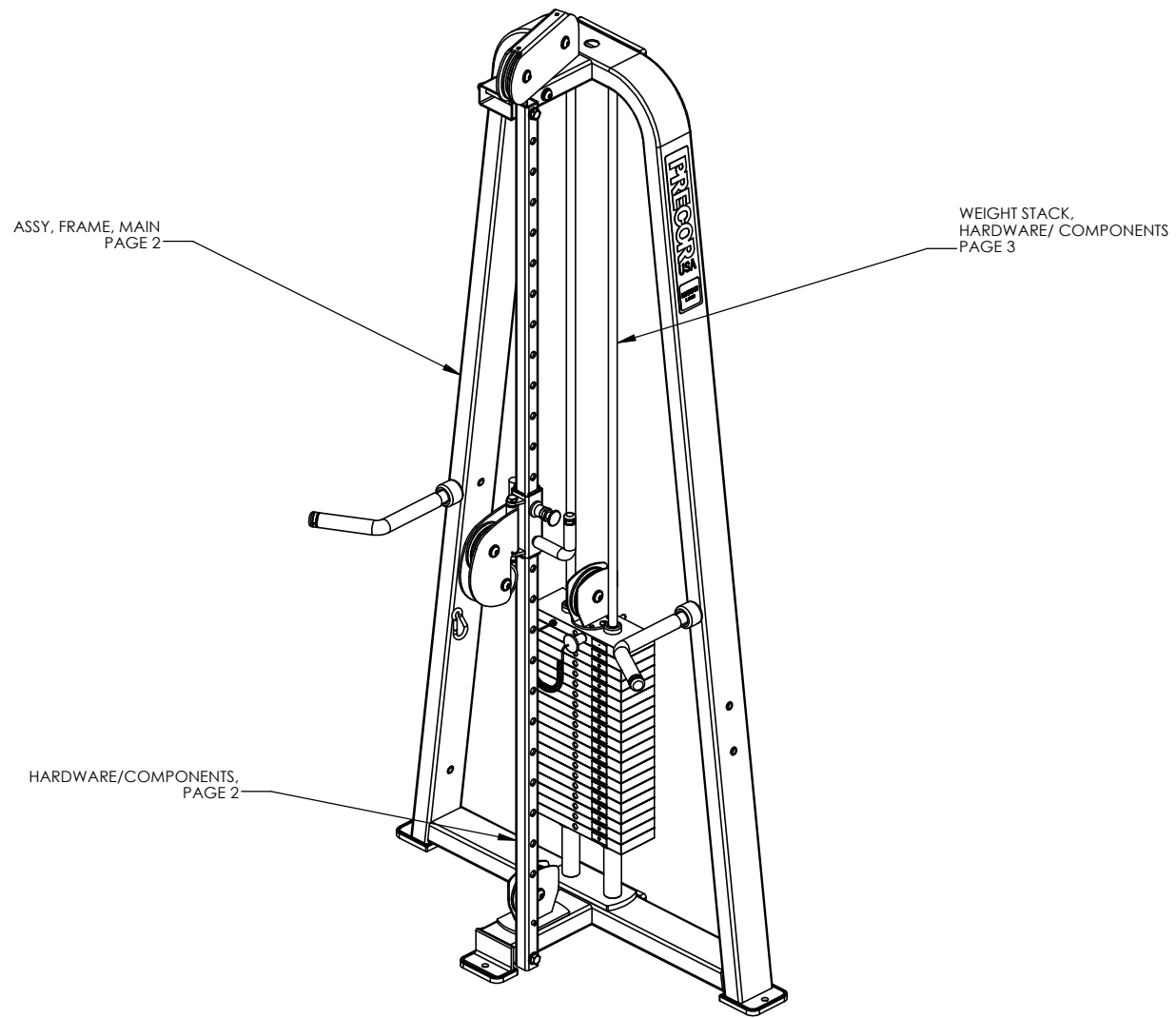

ASSY, FRAME, MAIN  
PAGE 2

WEIGHT STACK,  
HARDWARE/ COMPONENTS  
PAGE 3

HARDWARE/COMPONENTS,  
PAGE 2

P/N: CW34920-401		SUBREV: A
DRAWN BY: VLE	DATE: 06.24.09	SHEET 1 OF 3

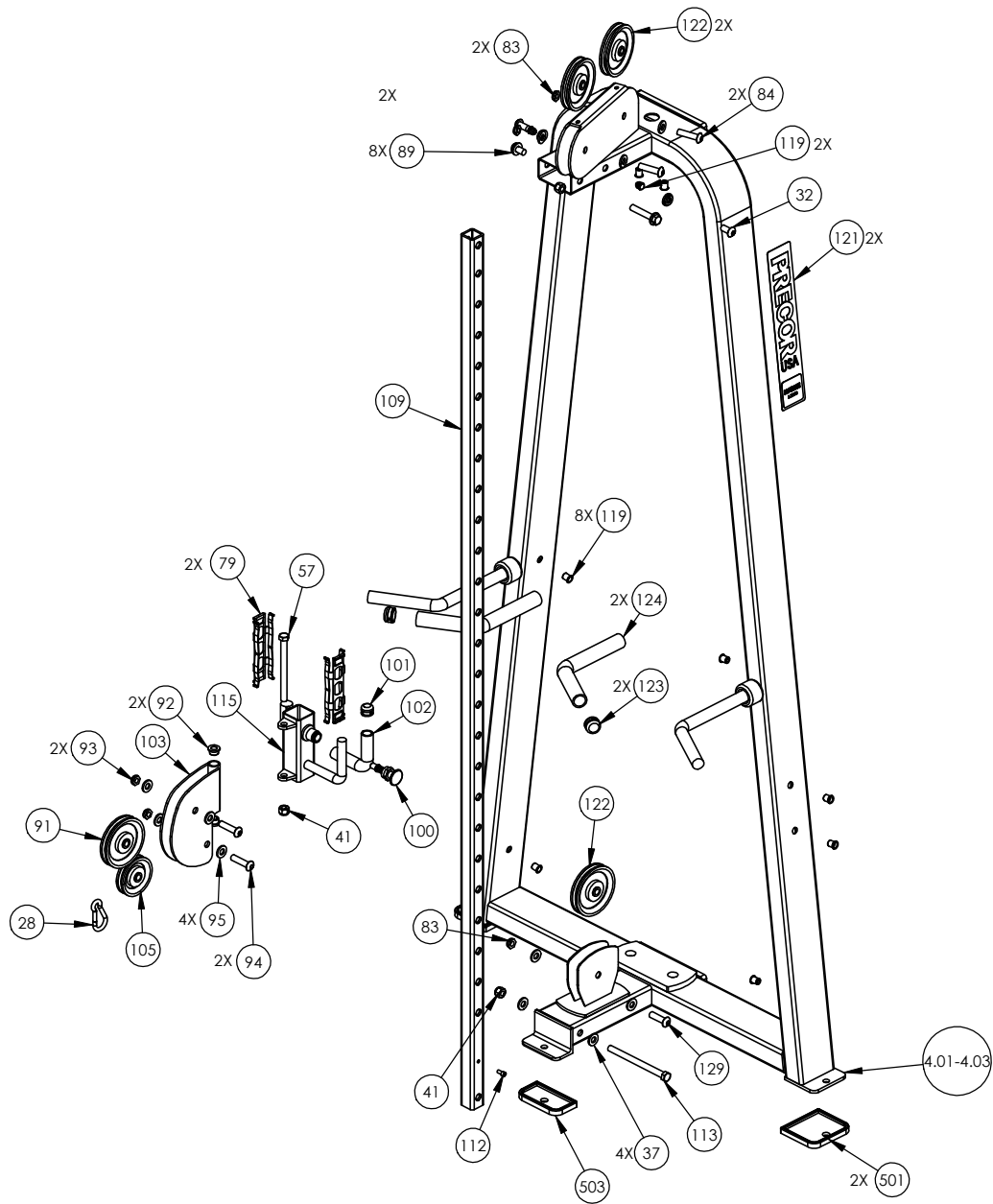

P/N: CW34920-401		SUBREV: A
DRAWN BY: VLE	DATE: 06.24.09	SHEET 2 OF 3

20

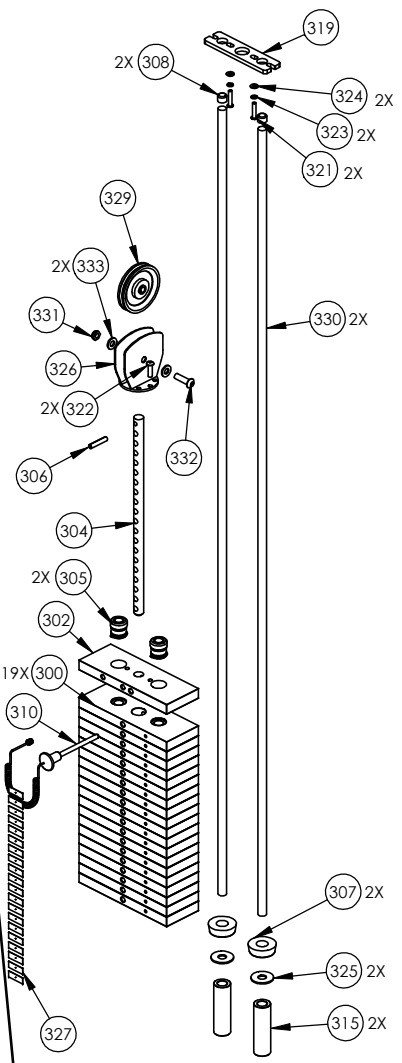
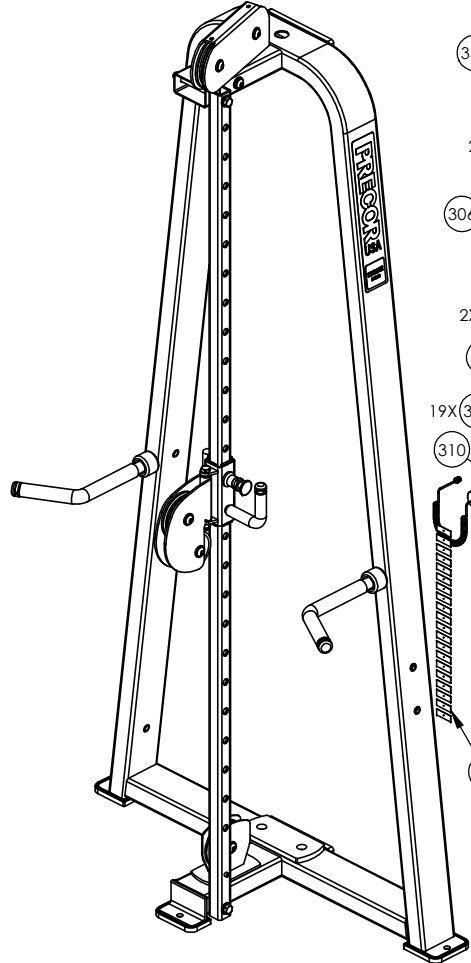

P/N: CW34920-401		SUBREV: A
DRAWN BY: VLE	DATE: 06.24.09	SHEET 3 OF 3